

INSTALLER: Must read through installation instructions provided!!!!

Item	Type	Min Qty
Concrete m3	1:2:4 or Equivalent	0.1

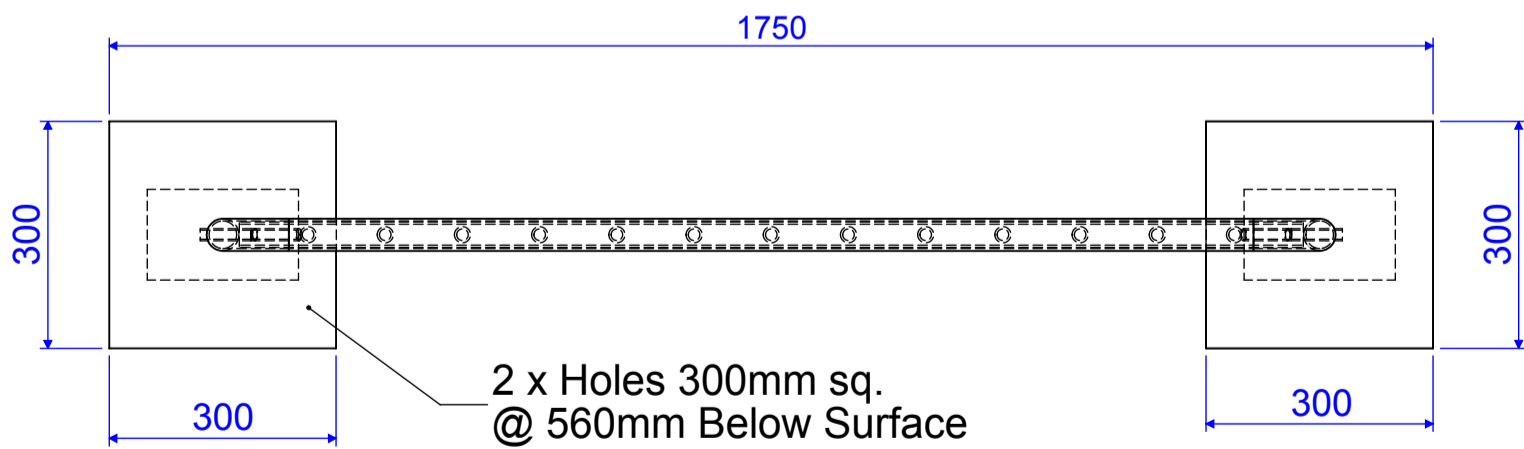

Current Drawing Status	Approved
Manufacturing Manual	90

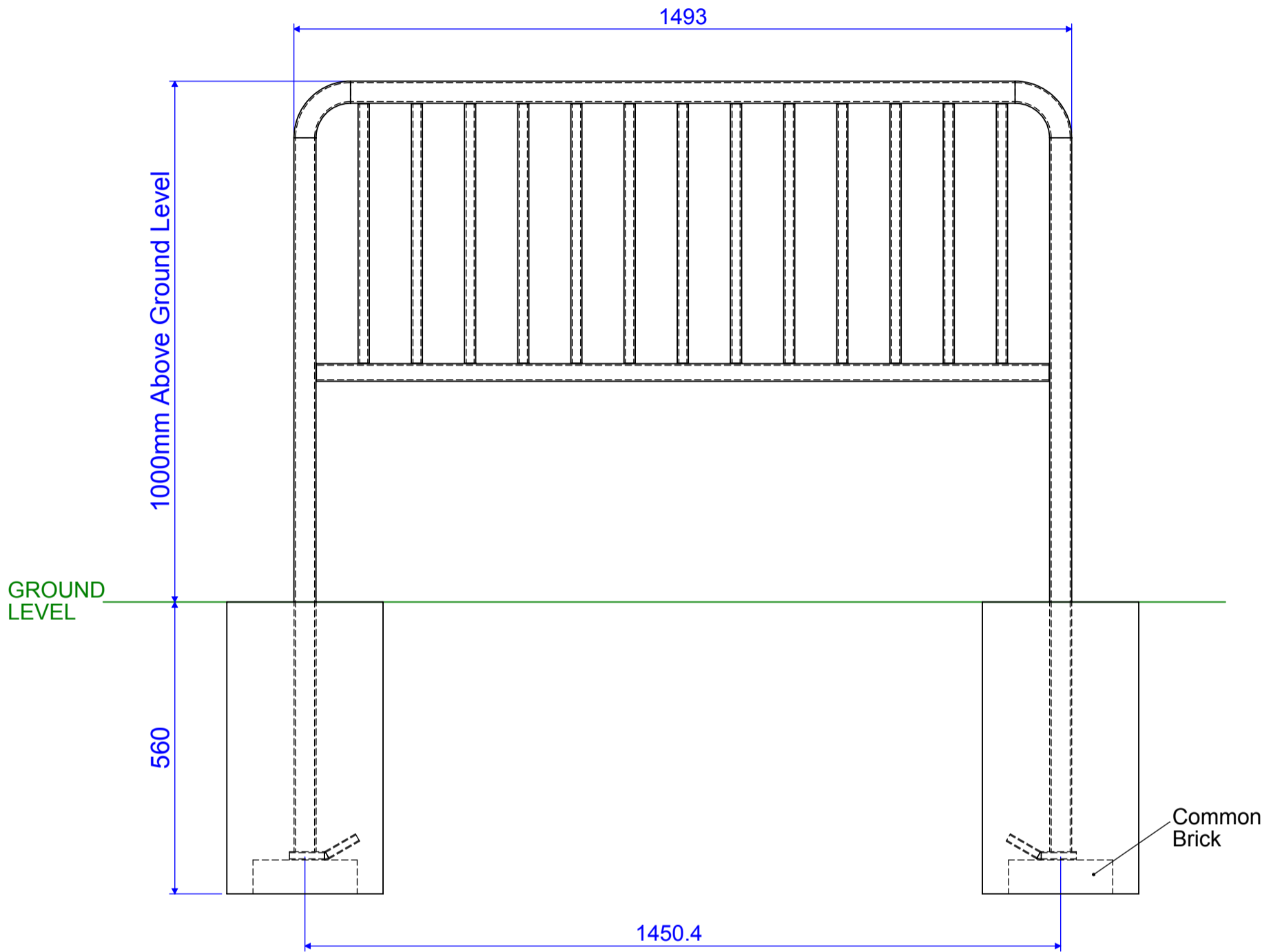

GL Jones Playground Ltd
Station Road, Bethesda
Gwynedd LL57 3NE
Tel: 01248 600372
info@gljones-playgrounds.co.uk
www.gljones-playgrounds.co.uk

	NAME
LASTSAVE	mike.roberts
DRAWN	Mike Roberts

DO NOT SCALE DRAWING REVISION 00

TITLE: Swing Barrier 1.5m Wide

This drawing is for guidance only and has been produced with the BS EN1176 & BS EN 1177 standards in mind. The installer will need to ensure compliance with their country's standards before using this drawing.

DWG NO.	A3
A111-001	©
DATE	SHEET 1
11/01/2016	

This drawing must not be copied or passed on to a third party without the specific permission of G.L. Jones Playgrounds Ltd. This drawing is supplied on the understanding that the installer has the required skills to ensure correct installation - G.L. Jones Playgrounds Ltd can only guarantee installations completed under their direct supervision.